

# SLA

FACTORY ACTIVATED

SLA | READY TO START

# REF BTX16



**12V** VOLTAGE - V

**230A** CCA - A

**14.7Ah** CAPACITY - Ah (20Hr)

**14Ah** CAPACITY - Ah (10Hr)

## TECHNOLOGY

- Designed according to AGM technology (Absorbed acid)
- VRLA battery type
- Activated and pre-charged batteries
- Homologated by OEM

## FEATURES

- AGM construction (Absorbed Glass Material)
- VRLA battery (Valve Regulated Lead Acid)
- Factory activated
- Environmentally friendly, spillproof design
- Multi-positional fitment
- Absolutely Maintenance free
- Sealed, no gas emission through venting hole (under normal operation)
- Ready & Easy to use
- No acid handling - Very safe
- Increased power & Extended life
- Extreme vibration resistance

## UPGRADE FOR

BTX16-BS

## WEIGHT

Battery (with acid) : Approx 5.16kg (11.36 lbs)

## MOUNTING ANGLE

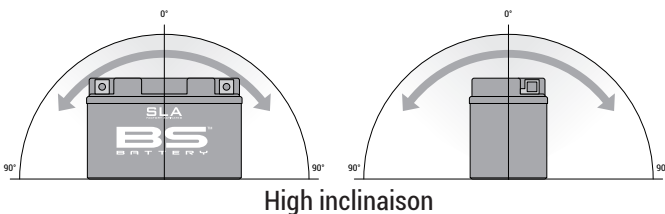

## DIMENSIONS

Length (A) : 150±2mm (5.91 in)  
 Width (B) : 87±2mm (3.43 in)  
 Container height : 161±2mm (6.34 in)  
 Total height (C) : 161±2mm (6.34 in)

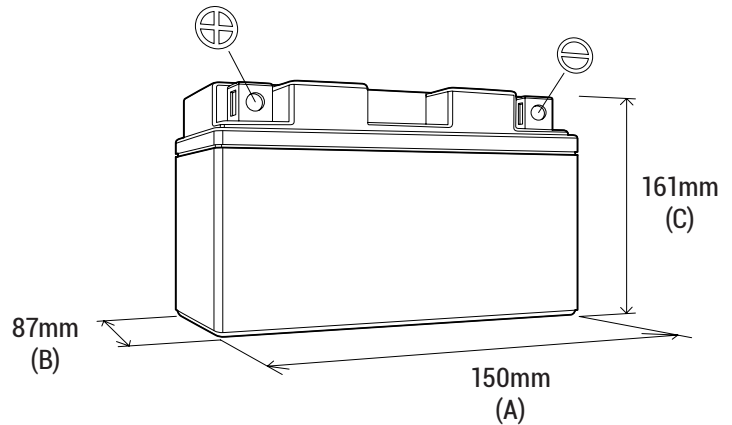

## TERMINALS

